



Serial Cables PCI Express PCI-AD-X16HE-PS-MD Adapter



PCI-AD-X16HE-PS-MD Transparent Adapter users guide
Version 0.8 (Preliminary)

Date: 5th March 2018

Table of Contents

DISCLAIMER	4
TERMS AND ACRONYMS	4
PCI-AD-X16HE-PS-MD HIGH LEVEL SPECIFICATION	5
PACKAGING	6
PRE-INSTALLATION QUESTIONS	6
PCIe SLOT DETERMINATION	6
PCI-AD-X16HE-PS-MD HOST / TARGET CONFIGURATION	6
OPERATING ENVIRONMENT.....	6
CABLE CONNECTIONS.....	6
<i>PCI Express 3.0 Cables</i>	6
<i>MiniSAS-HD Cables</i>	7
<i>Active Optical Cables (AOC)</i>	7
INSTALLATION	8
STEP 1 - UNPACK BOARD	8
STEP 2 - CHANGE PCIe BRACKET IF NECESSARY	8
STEP 3 - CONFIGURE THE BOARD FOR PROPER OPERATION	8
STEP 4 - INSTALL THE ADAPTER CARD.....	8
STEP 5 - INSTALLING AND REMOVING THE CABLE.....	8
<i>Connecting the Cable</i>	8
<i>Disconnecting the Cable</i>	9
STEP 6 - VERIFY INSTALLATION & LEDs.....	9
OPERATION	10
CONFIGURATION AND DIP SWITCHES.....	10
<i>DIP Switch Bank – Configuration</i>	10
USE CASES.....	11
<i>Use Case A - 1 Host – Single Expansion Configuration</i>	11
<i>Use Case B – 1 Host - Dual Expansion Configuration</i>	12
<i>Use Case C – 1 Host - Quad Expansion Configuration</i>	12
EEPROM AND FIRMWARE UPGRADE	13
IDENTIFYING THE CARD.....	13
SUPPORT	ERROR! BOOKMARK NOT DEFINED.
TECHNICAL INFORMATION	16
SIMPLIFIED SCHEMATICS	16
PCIe CABLE PORT SIGNALS	17
EXTERNAL PCIe x4 CABLE CONNECTOR PIN-OUT	17
PCIe CABLE PORT MAPPING	17
PCI-AD-X16HE-PS-MD PCIe X16 EDGE CONNECTOR PIN-OUT.....	18
COMPLIANCE AND REGULATORY TESTING	19
LIMITED WARRANTY	20
WARRANTY PERIOD.....	20
COVERAGE.....	20
SERVICE PROCEDURE	20

DISCLAIMER

SERIAL CABLES RESERVES THE RIGHT TO MAKE CHANGES WITHOUT FURTHER NOTICE TO ANY OF ITS PRODUCTS TO IMPROVE RELIABILITY, FUNCTION, OR DESIGN.

TO THE FULLEST EXTENT PERMITTED BY LAW, SERIAL CABLES WILL NOT BE LIABLE FOR ANY INDIRECT, INCIDENTAL, SPECIAL OR CONSEQUENTIAL DAMAGES (INCLUDING LOST PROFITS, LOST DATA, OR LOSS OF USE) ARISING OUT OF ANY USE OF SERIAL CABLES'S PRODUCTS, SOFTWARE OR SERVICE PROVIDED. SERIAL CABLES'S MAXIMUM LIABILITY WILL NOT EXCEED THE TOTAL AMOUNT PAID FOR THE PRODUCT BY THE PURCHASER.

PCI Express External Cabling specification 3.0 is as of the release of PCI-AD-X16HE-PS-MD not completed and ratified by the PCI-SIG. The PCI-AD-X16HE-PS-MD is designed to the new specification, but Serial Cables cannot guarantee the card will be compliant to the final 1.0 version. Serial Cables firmware tools can update the CMI implementation.

LIFE SUPPORT POLICY

SERIAL CABLES PRODUCTS ARE NOT AUTHORIZED FOR USE AS CRITICAL COMPONENTS IN LIFE SUPPORT DEVICES.

ENVIRONMENTAL POLICY

Serial Cables is minimizing the amount of printed documentation and software CDs in its shipments; please download additional documentation and software from www.SerialCables.com.

Terms and acronyms

Important terms and acronyms used in this manual

AOC	Active Optical Cable. PCIe fiber cable assembly.
CMI	Cable Management Interface. The 2-wire management interface for communication between subsystems connected by a PCIe 3.0 cable. Details can be found in the PCI-SIG External Cabling Specification 3.0.
CMI Controller	Microcontroller on the PCI-AD-X16HE-PS-MD used to manage and implement the CMI communications.
eXpressWare	Serial Cabless software stack for PCIe clustering and IO. Please visit www.SerialCables.com for more information.
Host mode	The card is installed in a root complex / Host PC.
Lane	One PCI Express Lane contains a differential pair for transmission and a differential pair for reception.
Link	A collection of one or more PCI Express Lanes providing the communication path between an Upstream and Downstream Port.
MiniSAS-HD	Standard cable without CMI support.
PCIe 3.0 cable	Cable compliant to the preliminary PCI-SIG External Cabling Specification 3.0. Support for CMI.
Port	PCIe Cable port. The PCI-AD-X16HE-PS-MD has four x4 ports, named P1, P2, P3, P4. These ports can be merged to two x8 ports, or one x16 port. The physical ports are identified by text on the PCIe brackets.
Target mode	The card is installed in an expansion chassis
Wake	A mechanism used by a downstream device to request the reapplication of main power when in the L2 Link state.

PCI-AD-X16HE-PS-MD High Level Specification

The PCI-AD-X16HE-PS-MD is a low profile, half-length PCIe adapter that can be configured as a Transparent Host Adapter card or a Target adapter card. Once installed in any server's or PC's PCI Express compliant slot, a PCI-AD-X16HE-PS-MD can connect to another PCI-AD-X16HE-PS-MD configured for Transparent Target operation or any target device compliant to the PCI Express External Cabling Specification 3.0. The PCI-AD-X16HE-PS-MD configured as a Transparent Target card can be installed in a PCI Express compliant expansion upstream slot. Please contact Serial Cables for a list of compliant expansion chassis. The PCI-AD-X16HE-PS-MD supports PCIe Gen1, Gen2 and Gen3 speeds and x1, x2, x4, x8 and x16 link-widths. The card will operate at the highest common speed shared between the slot and the card (Gen3) and the widest common link-width (x16).

- PCI Express Base Specification, Rev. 3.1.
- PCI Express CEM Specification, Rev. 3.0.
- PCI Express External Cabling specification 3.0 (Work in progress, rev 0.7)
- PCI Express Gen3 8.0 GT/s per lane signaling – 128 GT/s total signaling.
- PCI Express Gen3 x16 edge connector. The card installs in any PCI Express slot that has a physical x16 connector.
- Compliant with PCI Express Gen1 through Gen3 computers and IO systems, auto detection.
- The PCI-AD-X16HE-PS-MD supports transparent connections to IO systems (Host and Target operation).
- Quad SFF-8644 cable connector
- Cable port configurations, up to
 - One x16
 - Two x8
 - Four x4
- Microsemi Switchtec PFX PCI Express Gen3 chipset.
- 170 nanosecond cut-through latency port to port.
- Support for MiniSAS-HD copper cables between PCI-AD-X16HE-PS-MD cards.
- Support for PCI Express 3.0 copper cables with CMI.
- Support for active optical fibers up to 100 meters.
- Low profile, Half-length - PCI Express Electromechanical Specification, Rev 3.0.
- Dimensions 167.65mm (6.600 inches) x 68.90 mm (2.731 inches)
- Comes with both low profile and standard profile PCI Express bracket.
- Host clock isolation. Automatic support for host running CFC or SSC mode.
- VAUX powered board management controllers for flexible configuration and cable management.
- Flash recovery option. PFX Multi configuration support.
- Power consumption:
 - 12 Volt: Max 19.6 Watts without AOC attached.
 - 12 Volt: Max 26 Watts with 4 AOCs attached
 - +3.3 Volt: Not connected
 - +3.3 Volt AUX: 1 W
- Port power supply (per cable port): 3.3 Volt +/- 5%, 0.6 A
- Operating Temperature: 0°C - 55°C (32°F - 131°F), Air Flow: 150 LFM
- Operating Temperature with AOC: 0°C - 45°C (32°F - 113°F), Air Flow: 150 LFM
- Operating Temperature: 0°C - 50°C (32°F - 122°F), Air Flow: ~0 LFM
- Relative Humidity: 5% - 95% (non- condensing)
- Regulatory:
 - CE
 - EN-55032, EN 55024, Class A.
 - RoHS
 - FCC 15 Subpart B Class A.
 - WEEE
 - Pending Korean KC mark

Packaging

The PCI-AD-X16HE-PS-MD includes the following components.

- PCI-AD-X16HE-PS-MD Adapter Board
- Low profile bracket
- Anti-static bag
- Getting started guide

Pre-Installation Questions

Certain steps should be taken prior to installing the PCI-AD-X16HE-PS-MD. You should determine the following configuration requirements.

- Which PCIe slot and system will the card be installed in?
- Will the board act as a host adapter or target adapter?
- What is the speed and link width of the slot that the card will be installed in?
- What is the operating environment in which the card will be installed?
- What type and length of cables will be used?
- How to establish proper operational conditions, temperature and air-flow.

PCIe Slot Determination

The PCI-AD-X16HE-PS-MD supports PCIe Gen1, Gen2 and Gen3 speeds and x1, x2, x4, x8 and x16 link-widths. The slot width and speed will affect the performance of the card. The card can be physically installed in a x4, x8 or x16 connector. The card will auto configure to the slot speed and width.

PCI-AD-X16HE-PS-MD Host / Target Configuration

The PCI-AD-X16HE-PS-MD can act as either a host adapter or target adapter. The PCI-AD-X16HE-PS-MD has a DIP switch bank to control these functions. The DIP switch labeled SW1 can be found close to the upper edge of the board. The main configuration options are host or target operations. The default DIP switch setting is transparent host x16 operations. Additional settings are target operations, two x8 links, four x4 links, alternative edge clock routing and quad edge target.

Operating Environment

To maximize life time for the product and maintain the warranty, please honor the specified operating temperature and make sure the specified air flow is present. Special care should be considered when PCI-AD-X16HE-PS-MD is used in office type cabinets in combination with other high energy consuming PCIe devices, e.g. not active cooled GPUs:

Operating Temperature: 0°C - 55°C (32°F - 131°F), Air Flow: 150 LFM

Operating Temperature with AOC: 0°C - 45°C (32°F - 113°F), Air Flow: 150 LFM

Operating Temperature: 0°C - 50°C (32°F - 122°F), Air Flow: ~0 LFM

Relative Humidity: 5% - 95% (non- condensing)

Cable Connections

The PCI-AD-X16HE-PS-MD is designed to support both long and short copper cables as well as active optical cables (AOC). The default configuration supports cables between 0.5 and 9 meters or fiber cables. If you are connecting the PCI-AD-X16HE-PS-MD to a compliant target device not designed by Serial Cables, other settings or limitations may apply.

The PCI-AD-X16HE-PS-MD cable connector is compliant to the SFF-8644 industry specification and supports standard x4/x8 Mini-SAS HD cables or x4/x8 PCI Express 3.0 cables compliant to the PCIe External Cabling Specification 3.0. Four x4 or two x8 cables are needed for full PCIe x16 connectivity.

PCI Express 3.0 Cables

When used with cables compliant to the new PCIe External Cable standard 3.0, the PCI-AD-X16HE-PS-MD card will transmit a CMI Reset message downstream. The card can be connected to a PCI-AD-X16HE-PS-MD in Target mode or any PCIe device compliant to the new cable standard. Support for additional CMI messages are being implemented and will be available with the next firmware maintenance release, please contact Serial Cables for details.

MiniSAS-HD Cables

When used with standard MiniSAS-HD cables that does not support the new CMI functionality, the onboard CPU will synthesize a PCIe #CPERST and forward it to the downstream PCI-AD-X16HE-PS-MD card. CWAKE and CPOWERON is not supported using standard MiniSAS-HD cables.

Active Optical Cables (AOC)

The PCI-AD-X16HE-PS-MD card is compliant with active fiber optic cables up to 100 meters. Special configuration of the card needs to be performed for working with long fibers (Contact Serial Cables). CWAKE and CPOWERON is not supported using standard AOC cables.

Installation

Step 1 - Unpack board

The PCI-AD-X16HE-PS-MD card is shipped in an anti-static bag to prevent static electricity damage. The card should only be removed from the bag after ensuring that anti-static precautions are taken. Static electricity from your clothes or work environment can damage your PCI Express adapter card or your PC. Always wear a grounded anti-static wrist strap while opening the PC and when the PCI-AD-X16HE-PS-MD is removed from the anti-static bag. Unpack the PCI-AD-X16HE-PS-MD from the anti-static bag using proper anti-static procedures.



Step 2 - Change PCIe Bracket if necessary

The PCI-AD-X16HE-PS-MD package includes a standard and low-profile PCI Express bracket. By default, the standard height bracket is installed on the board. If you need to replace the mounted bracket with a low-profile bracket, carefully unscrew the two mounting screws to remove the full height bracket. Save the two mounting screws and replace the bracket with the low-profile bracket. Use the two mounting screws to install the low-profile bracket. The screws should be carefully tightened, but be careful not to over-tighten. Make sure you are properly grounded to avoid static discharges that may destroy the adapter card before performing this procedure.

Step 3 - Configure the Board for Proper Operation

Set the DIP switch settings for proper operation depends on the firmware. Please refer to the section Configuration and DIP Switches on page 10 for details.

Step 4 - Install the Adapter Card

Before installing the adapter card, make sure you are properly grounded to avoid static discharges that may destroy your computer or the adapter card. Ensure you are properly grounded before opening your computer or the anti-static bag containing the PCI-AD-X16HE-PS-MD. Please follow your computer's or expansion chassis manual on how to install a PCI Express card.



The PCI-AD-X16HE-PS-MD Adapter card can be installed into any PCI Express x16 slot. The PCI-AD-X16HE-PS-MD supports PCI Express Gen1, Gen2 and Gen3 signaling. NOTE: A Gen3 slot is recommended as it typically doubles the performance compared to a Gen2 slot. The PCI-AD-X16HE-PS-MD is an x16 card, so maximum performance will only be attained if the slot provides full electrical x16 signaling.

The PCI-AD-X16HE-PS-MD supports hosts using either spread spectrum or constant frequency clocking. The card implements clock isolation.

Step 5 - Installing and Removing the Cable

Installing and removing cables should be done with both host and expansion system powered off. Please contact your Serial Cables representative if you intend to continuously connect and disconnect the PCI Express cables.

Connecting the Cable

Please carefully install the cable connector into the connector housing on the PCI-AD-X16HE-PS-MD adapter card. To install the cable, match the cable house with the connector on the PCI-AD-X16HE-PS-MD adapter card. Use even pressure to insert the connector until it is secure. Adhere to ESD guidelines when installing the cables to ensure you don't damage the board. Computer cables should always use strain relief to protect the connected equipment from excessive force on the cable. This is especially important for cables between racks. Note that for wider than x4 connections, the same cable-ports (ie port 1 through 4) should be used on both host and target for each individual cable, to ensure that the cards properly link up as x8 or x16.

The PCI-AD-X16HE-PS-MD supports both copper and active optical cables (AOC). Project targets can be found in Table 1 below. Long cable qualification in progress, please contact Serial Cables for details.

Cable	Speed	Distance
Copper MiniSAS-HD	Gen3	9 meters
Copper MiniSAS-HD	Gen1	12 meters
Copper PCIe 3.0 cable	Gen3	TBD

Fiber optic (AOC)	Gen3	50 meters / 100 meters
-------------------	------	------------------------

Table 1: Cable Specifications

Disconnecting the Cable

Please carefully pull the release tab to release the cable from the locking latches and gently pull the cable out of the connector guides.

Step 6 - Verify Installation & LEDs

The PCI-AD-X16HE-PS-MD comes with 4 bi-color LEDs which show the corresponding cable port status according to Table 2: LED below.

The LEDs are visible through cut-outs in the PCIe bracket on each side of the cable connector block.

LED color	Function
Off	No cable installed
Yellow	Cable installed, no link
Green	Cable installed, link gen 3
Green blinking	Cable installed, link gen 1/2

Table 2: LED behavior

Operation

Configuration and DIP Switches

The PCI-AD-X16HE-PS-MD has one bank of 8 DIP switches. The default factory setting for the PCI-AD-X16HE-PS-MD is Transparent Host mode, single (up to x16) link connection.

The PCI-AD-X16HE-PS-MD has DIP switches for setting special modes or operations, the meaning of each DIP switch depends on the loaded firmware. Please carefully read the documentation shipping with the card before modifying any DIP switch settings. Please pay close attention to ON and OFF positions written on the DIP switch.

DIP Switch Bank – Configuration

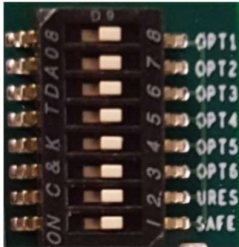

Figure 1: DIP Switch shows the DIP switch for the PCI-AD-X16HE-PS-MD. It is used to configure the adapter card. Please leave all undocumented DIP switches in the default position. Table 3: DIP Switch settings shows all the various DIP switch settings for the PCI-AD-X16HE-PS-MD.

Figure 1: DIP Switch

DIP no.	Name	Description	ON	OFF	Default
1-4	OPT1-4	Configuration selector, details below			OFF
5	OPT5	CMI Disable	Will disable the CMI interface.	CMI will be used if a PCIe 3.0 cable is detected	OFF
6	OPT6	Reserved for future use			OFF
7	URES	Holds the management processors in reset	Board management is held in reset	Normal operation	OFF
8	SAFE	Enables the card to boot if the EEPROM has been corrupted	Safe EEPROM	Normal operation	OFF

Table 3: DIP Switch settings

Note: DIP switch configuration options may be changed in the future versions. Please always consult the latest user guide for details.

Use Cases Summary and Settings

Table 4: Use Case DIP switch settings below gives an overview of the various use cases, settings and limitations.

Use case	Description	Host DIP switch setting	Target DIP switch setting
A	One Host system having a PCI-AD-X16HE-PS-MD in Host mode connecting to one PCI-AD-X16HE-PS-MD in Target mode or a 3rd party expansion system.	OPT1: Transparent ON	Single setting for all Target configurations except alternative clock routing
B	One Host system having a PCI-AD-X16HE-PS-MD in Host mode connecting to two PCI-AD-X16HE-PS-MDs in Target mode or two 3rd party expansion systems.	OPT1: Transparent ON OPT3 on to enable two x8 links	Transparent ON Target ON OPT5 on to enable alternative target clock routing
C	One Host system having a PCI-AD-X16HE-PS-MD in Host mode connecting to four PCI-AD-X16HE-PS-MDs in Target mode or four 3rd party expansion systems.	OPT1: Transparent ON OPT4 on to enable four x4 links	All other off

Table 4: Use Case DIP switch settings

Use Cases

The PCI-AD-X16HE-PS-MD card may be used as both a Host card and a Target card. A Host and Target card can be used as a pair or the Host card can be used with a compliant Target device. The supported use cases and the DIP switch settings are summarized in Table 4: Use Case DIP switch settings. **Please use the table to identify the correct DIP switch settings.**

Use Case A - 1 Host – Single Expansion Configuration

The Host system has a PCI-AD-X16HE-PS-MD adapter configured for Host operation and a direct x4, x8 or x16 link to a PCI-AD-X16HE-PS-MD configured for Target operation.

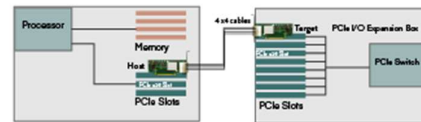

Figure 2: Use Case A

Connecting the cables for single expansion, x16 link

To establish an x16 link, a given port number should be connected to the same port number on the other card.

Always connect a cable from Port #x to Port #x

Port Host A	Port Expansion
P1	P1
P2	P2
P3	P3
P4	P4

Table 5: Required x16 cabling

A failure connecting any of the cables will cause the link to re-train to x8 or x4.

Connecting the cables for single expansion, x8 link

To establish an x8 link, please select one of the alternatives below. Select alternative 1, 2, 3 or 4.

Alternatives	Host Port	Expansion Port
1	P1	P1
	P2	P2
2	P1	P3
	P2	P4
3	P3	P1
	P4	P2
4	P3	P3
	P4	P4

Table 6: Alternative x8 cabling

Connecting the cables for 2 Node Configurations, x4 link

To establish an x4 link when in dual port mode, please connect any port on the Host card to Port P1 or P4 on the Target card.

Use Case B – 1 Host - Dual Expansion Configuration

The host has a PCI-AD-X16HE-PS-MD adapter configured for Host operation and a direct x4 or x8 cable connection is used to connect two independent downstream target systems.

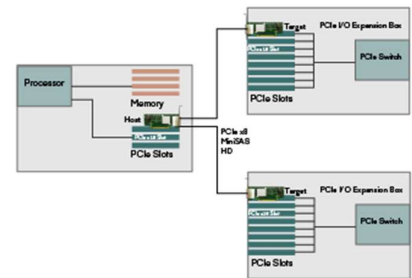

Figure 3: Use Case B

Connecting the cables for Single Node Dual expansion, x8 link

Connect the cables between the host and expansion as described above for x8 connectivity. Connect the second expansion to the free ports. Always connect port P1 + P2 to P1 + P2 or P3 + P4

Use Case C – 1 Host - Quad Expansion Configuration

The host has a PCI-AD-X16HE-PS-MD adapter configured for Host mode and a direct x4 cable connection is used between the Host systems and each expansion Chassis. The PCI-AD-X16HE-PS-MD in the Expansion Chassis is configured for Target mode.

DIP Switch setting for Single Node Four Expansion Configuration

NB: Please contact Serial Cables for more information on DIP switches for this setting. Not supported by the current firmware.

Connecting the cables for Single Node Four expansion, x4 link

Connect any port on the Host card to port P1 or P4 on the target card.

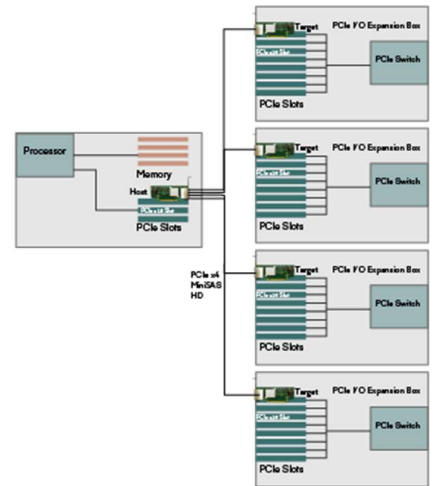

Figure 4: Use Case C

EEPROM and Firmware Upgrade

The PCI-AD-X16HE-PS-MD design uses a microcontroller to implement the PCIe CMI protocol and other maintenance functions. Serial Cables may from time to time publish updated firmware for the microcontroller or EEPROM data for the card. Please contact Serial Cables for instructions on how to upgrade the PCI-AD-X16HE-PS-MD. Please note that standard Microsemi firmware tools cannot be used to upgrade the firmware.

Identifying the Card

The card has a label-sticker with the serial number in the format 'PCI-AD-X16HE-PS-MD-YY-ZZZZZ', where YY denotes the card revision (e.g. BB) and ZZZZZ denotes the serialized production number (e.g. 012345) – this whole string makes up the serial number of the card (i.e. PCI-AD-X16HE-PS-MD-BB-012345).

You can also get this information using `lspci` in Linux:

First, identify the devices for the Serial Cables Host card:

```
# lspci | grep "Device 8532"

01:00.0 PCI bridge: PMC-Sierra Inc. Device 8532
01:00.1 Memory controller: PMC-Sierra Inc. Device 8532
02:00.0 PCI bridge: PMC-Sierra Inc. Device 8532
```

Then run `lspci`, and identify the card. It will show up as something like

```

# lspci -s 1:0.0 -v
01:00.0 PCI bridge: PMC-Sierra Inc. Device 8532 (prog-if 00 [Normal decode])
  Flags: bus master, fast devsel, latency 0, IRQ 25
  Bus: primary=01, secondary=02, subordinate=03, sec-latency=0
  I/O behind bridge: 00002000-00002fff
  Prefetchable memory behind bridge: 00000000df200000-00000000df3fffff
  Capabilities: [40] Express Upstream Port, MSI 00
  Capabilities: [7c] MSI: Enable+ Count=1/8 Maskable- 64bit+
  Capabilities: [8c] Power Management version 3
  Capabilities: [94] Subsystem: Serial Cables Interconnect Solutions AS Device 0830
  Capabilities: [100] Advanced Error Reporting
  Capabilities: [138] Power Budgeting <?>
  Capabilities: [148] #12
  Capabilities: [178] #19
  Capabilities: [1a4] Device Serial Number 00-00-42-42-00-00-00-ff
  Capabilities: [1b0] Latency Tolerance Reporting
  Capabilities: [1b8] Access Control Services
  Capabilities: [7f8] Vendor Specific Information: ID=ffff Rev=1 Len=808 <?>
  Kernel driver in use: pcieport
  Kernel modules: shpchp

# lspci -s 1:0.1 -v
01:00.1 Memory controller: PMC-Sierra Inc. Device 8532
  Subsystem: Serial Cables Interconnect Solutions AS Device 0830
  Flags: bus master, fast devsel, latency 0
  Memory at f7800000 (64-bit, non-prefetchable) [size=4M]
  Capabilities: [40] MSI: Enable- Count=1/4 Maskable- 64bit+
  Capabilities: [50] MSI-X: Enable- Count=4 Masked-
  Capabilities: [5c] Power Management version 3
  Capabilities: [64] Express Endpoint, MSI 00
  Capabilities: [100] Advanced Error Reporting
  Capabilities: [138] Device Serial Number 00-00-42-42-00-00-00-ff
  Capabilities: [144] Access Control Services

# lspci -s 2:0.0 -v
02:00.0 PCI bridge: PMC-Sierra Inc. Device 8532 (prog-if 00 [Normal decode])
  Flags: bus master, fast devsel, latency 0, IRQ 26
  Bus: primary=02, secondary=03, subordinate=03, sec-latency=0
  I/O behind bridge: 00002000-00002fff
  Prefetchable memory behind bridge: 00000000df200000-00000000df3fffff
  Capabilities: [40] Express Downstream Port (Slot+), MSI 00
  Capabilities: [7c] MSI: Enable+ Count=1/8 Maskable- 64bit+
  Capabilities: [8c] Power Management version 3
  Capabilities: [94] Subsystem: Serial Cables Interconnect Solutions AS Device 0830
  Capabilities: [100] Advanced Error Reporting
  Capabilities: [138] Power Budgeting <?>
  Capabilities: [148] #12
  Capabilities: [178] #19
  Capabilities: [1a4] Device Serial Number 00-00-42-42-00-00-00-ff
  Capabilities: [1b0] Downstream Port Containment
  Capabilities: [1bc] Access Control Services
  Capabilities: [7f8] Vendor Specific Information: ID=ffff Rev=1 Len=808 <?>
  Kernel driver in use: pcieport
  Kernel modules: shpchp

```

Second, do

```
# lspci -s 1:0.0 -v | grep -E "Subsystem|Serial"
Capabilities: [a4] Subsystem: Serial Cables Interconnect Solutions AS Device 0832
Capabilities: [100] Device Serial Number 00-00-42-42-00-00-00-ff
```

This shows the card as revision 0x4242 (hexadecimal values of the 'BB' letters in the ASCII table), with the production number 0x000000ff (00000255 in decimal).

Technical Information

Simplified schematics

The figure below shows the PCI-AD-x16HE-PS-MD simplified schematics. Only the main functions are shown.

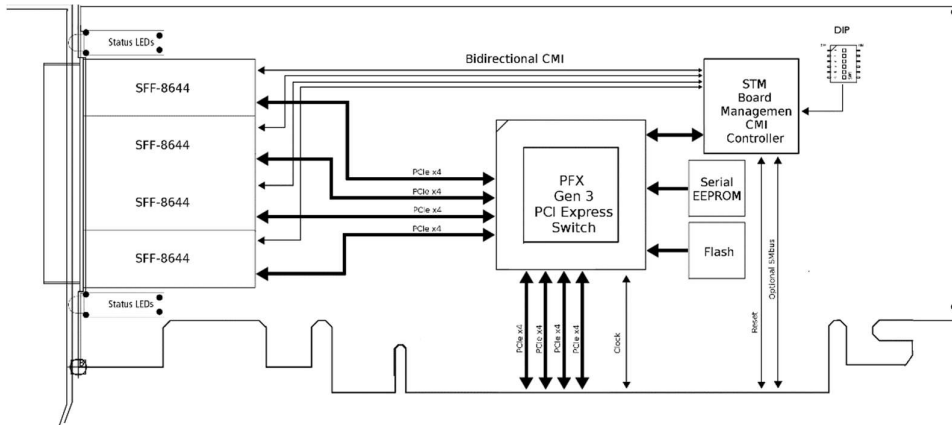

Figure 5: PCI-AD-X16HE-PS-MD Simplified Schematics

PCIe Cable Port Signals

The external PCI Express SFF-8644 cable connector supports the following signals:

- PETpN/PETnN: PCI Express Transmitter pairs, labeled where N is the Lane number (starting with 0); “p” is the true signal while “n” is the complement signal.
- PERpN/PERnN: PCI Express Receiver pairs, labeled where N is the Lane number (starting with 0); “p” is the true signal while “n” is the complement signal.
- PWR: Power to support AOC and signal conditioning components within the cable assembly.
- MGTPWR: Power supplied to the connector for cable management components that are needed while the link is not active. This needs to be active if the subsystem has power.
- CBLPRSNT#: Cable present detect, an active-low signal pulled-down by the cable when it is inserted into the PCI-AD-X16HE-PS-MD connector.
- CADDR: Signal used to configure the upstream cable management device address.
- CINT#: Signal asserted by the cable assembly to indicate a need for service via the CMI controller.
- CMISDA: Management interface data line. Used for both initial link setup and sideband messages when used with CMI compliant cables.
- CMISCL: Management interface clock line. Used for both initial link setup and sideband messages when used with CMI compliant cables.

External PCIe x4 Cable Connector Pin-Out

Row					Column				
	9	8	7	6	5	4	3	2	1
D	GND	PETn2	PETp2	GND	PETn1	PETp1	GND	MGTPWR	PWR
C	GND	PETn3	PETp3	GND	PETn0	PETp0	GND	CMISDA	CMISCL
B	GND	PERn2	PERp2	GND	PERn1	PERp1	GND	CBLPRSNT#	PWR
A	GND	PERn3	PERp3	GND	PERn0	PERp0	GND	CINT#	CADDR

Table 7; External PCIe x4 cable Pin-Out

PCIe Cable Port Mapping

The PCI-AD-X16HE-PS-MD card have a quad SFF-8644 connector. The table below show the signal / port map.

Cable Port	x16	Dual x8	Quad x4	PCIe 3.0 Cable Pin
1	L15	L7	L3	TX3/RX3
	L14	L6	L2	TX2/RX2
	L13	L5	L1	TX3/RX1
	L12	L4	L0	TX0/RX0
2	L11	L3	L3	TX3/RX3
	L10	L2	L2	TX2/RX2
	L9	L1	L1	TX3/RX1
	L8	L0	L0	TX0/RX0
3	L7	L7	L3	TX3/RX3
	L6	L6	L2	TX2/RX2
	L5	L5	L1	TX3/RX1
	L4	L4	L0	TX0/RX0
4	L3	L3	L3	TX3/RX3
	L2	L2	L2	TX2/RX2
	L1	L1	L1	TX3/RX1
	L0	L0	L0	TX0/RX0
Lx – PCIe lane X, Cable port is ref PCIe bracket marking				

Table 8 : PCIe Cable Port Mapping

PCI-AD-X16HE-PS-MD PCIe x16 Edge Connector Pin-Out

The PCI-AD-X16HE-PS-MD Edge connector follows PCI Express CEM Specification, Rev. 3.0 section 6 – Card Connector Specification. Signal names are shown in Table 9. In host mode, the PCI-AD-X16HE-PS-MD is PCIe SIG compliant. The signals in **bold** are bi-directional, where the direction depends on if the card is configured for host or target mode. In the case where the PXH832 is configured as a target adapter in an expansion chassis, it will provide a 100 MHz, non-SSC, reference clock on the REFCLK+/REFCLK- pins. The shaded signals TDI and TDO are normally tri-stated, but can be configured to provide a 100 MHz, non-SSC, reference clock for PCIe expansion chassis utilizing these pins instead.

Pin	Side B	Description	Side A	Description
1	+12		PRSNT1#	
2	+12		+12	
3	+12		+12	
4	GND		GND	
5	SMCLK	BMC	TCK	NC
6	SMDAT	BMC	TDI	O Ref clock +
7	GND		TDO	O Ref clock -
8	+3,3V	PWR	TMS	NC
9	TRST#	NC	+3,3	PWR
10	+3,3V aux	Standby	+3,3	PWR
11	WAKE#	Wake up	PERST#	Reset
12		NC	GND	
13	GND		REFCLK+	Ref clock +
14	PERp0		REFCLK-	Ref clock -
15	PERn0		GND	
16	GND		PETp0	
17	PRSNT2#		PETn0	
18	GND		GND	
19	PERp1			NC
20	PERn1		GND	
21	GND		PETp1	
22	GND		PETn1	
23	PERp2		GND	
24	PERn2		GND	
25	GND		PETp2	
26	GND		PETn2	
27	PERp3		GND	
28	PERn3		GND	
29	GND		PETp3	
30		NC	PETn3	
31	PRSNT2#		GND	
32	GND			NC
33	PERp4			NC
34	PERn4		GND	
35	GND		PETp4	
36	GND		PETn4	
37	PERp5		GND	
38	PERn5		GND	
39	GND		PETp5	
40	GND		PETn5	
41	PERp6		GND	
42	PERn6		GND	
43	GND		PETp6	

Pin	Side B	Description	Side A	Description
44	GND		PETn6	
45	PERp7		GND	
46	PERn7		GND	
47	GND		PETp7	
48	PRSNT2#		PETn7	
49	GND		GND	
50	PERp8		NC	
51	PERn8		GND	
52	GND		PETp8	
53	GND		PETn8	
54	PERp9		GND	
55	PERn9		GND	
56	GND		PETp9	
57	GND		PETn9	
58	PERp10		GND	
59	PERn10		GND	
60	GND		PETp10	
61	GND		PETn10	
62	PERp11		GND	
63	PERn11		GND	
64	GND		PETp11	
65	GND		PETn11	
66	PERp12		GND	
67	PERn12		GND	
68	GND		PETp12	
69	GND		PETn12	
70	PERp13		GND	
71	PERn13		GND	
72	GND		PETp13	
73	GND		PETn13	
74	PERp14		GND	
75	PERn14		GND	
76	GND		PETp14	
77	GND		PETn14	
78	PERp15		GND	
79	PERn15		GND	
80	GND		PETp15	
81	PRSNT2#		PETn15	
82		NC	GND	

Table 9: PCIe Edge Connector Pin-Out

Compliance and Regulatory Testing

EMC Compliance

The Serial Cables PCI Express PCI-AD-X16HE-PS-MD adapter is tested to the following relevant test standards for PCI Express cards, telecommunication and industry equipment installed in a standard PC:

EN 55032
EN 55024, Class A



This does not ensure that it will comply with these standards in any random PC. It is the responsibility of the integrator to ensure that their products are compliant with all regulations where their product will be used.

RoHS Compliance

The Serial Cables PCI-AD-X16HE-PS-MD is RoHS compliant. A Compliance certificate issued by the manufacturer is available upon request.



FCC Class A

This equipment is tested and found to comply with the limits for a Class A digital device, pursuant to part 15 of the FCC Rules.



Limited Warranty

Serial Cables warrants this product to be free from manufacturing defects under the following terms:

Warranty Period

Serial Cables warrants the product for one (1) year from the date of purchase. Extended warranties are available.

Coverage

To the extent permitted by applicable law, this warranty does not apply to:

- Damages caused by operator error or non-compliance with instructions available for the product.
- Use or attempt to use or program firmware not approved by Serial Cables.
- Damage which results from accident, abuse, misuse, neglected improper handling or improper installation; moisture, corrosive environments, high voltage surges, shipping or abnormal working conditions.
- Damages which results from violating the specified operating or storage temperatures and airflow.
- Damages caused by acts of nature, e.g. floods, storms, fire, or earthquakes.
- Damage caused by any power source out of range or not provided with the product.
- Normal wear and tear.
- Attempts to repair, modify, open or upgrade the product by personnel or agents not authorized by Serial Cables.
- Products that have had the product serial number tampered with or removed.
- Damage to the product caused by products not supplied by Serial Cables.

Service Procedure

If the product proves defective during the Warranty Period, you should contact the seller that supplied you with the product, or if you purchased it directly from Serial Cables, email support@serialcables.com to obtain a valid RMA number and instructions.

Products returned to Serial Cables without a proper RMA number will not be serviced under this warranty.